

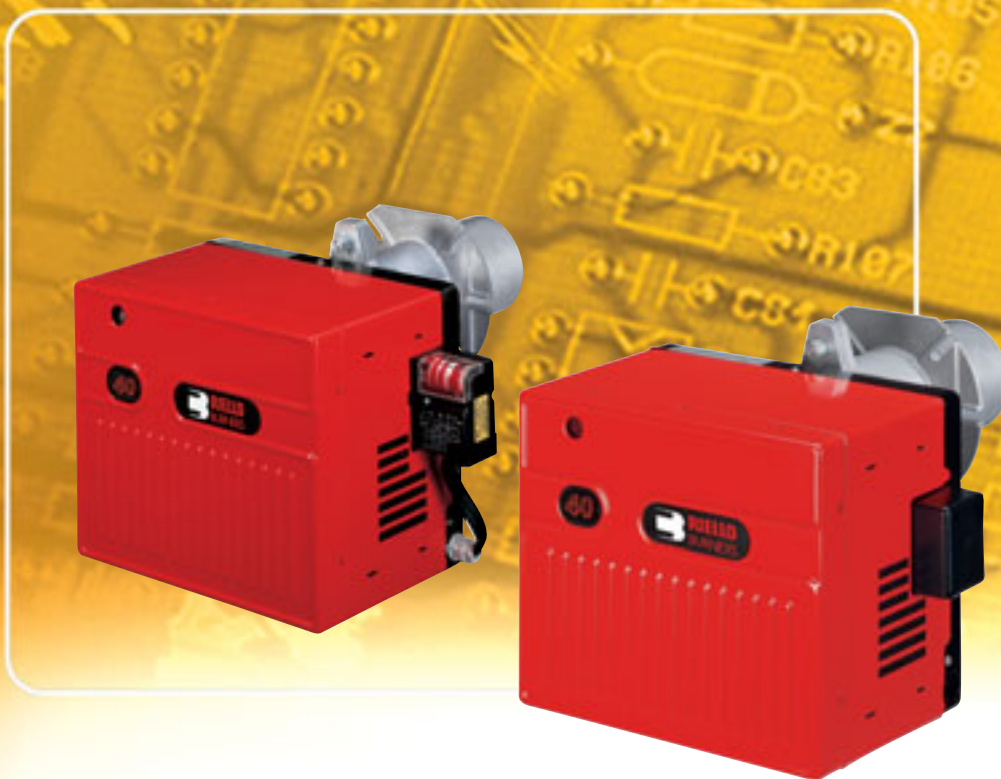

TWO STAGE GAS BURNERS

▶ RIELLO 40 FSD SERIES

▶ FS5D	12/23 ÷ 58 kW
▶ FS20D	58/81 ÷ 220 kW



The Riello 40 FSD series of two stage gas burners, is a complete range of products developed to respond to any request for light industrial process. The Riello 40 FSD series is available in two different models, with an output ranging from 12 to 220 kW, divided in two different structures.

All the models use the same components designed by Riello for the Riello 40 FSD series. The high quality level guarantees safe working.

The Riello 40 FSD burners are fitted with a microprocessor - based flame control panel, with diagnostic functions.

In developing these burners, special attention was paid to reducing noise, to the ease of installation and adjustment, to obtaining the smallest size possible to fit into any sort of boiler available on the market.

All the models are approved by the EN 676 European Standard and conform to European Directives for EMC, Low Voltage, Machinery and Boiler Efficiency.

All the Riello 40 FSD burners are tested before leaving the factory.



TECHNICAL DATA

Model		▼ FS5D	▼ FS20D
Burner operation mode		Two stage	
Modulation ratio at max. output		--	
Servomotor	type	R.B.L.	BERGER
	run time	6 - 28	13
Heat output	kW	12/23 - 58	58/81 - 220
	Mcal/h	10/20 - 50	50/70 - 189
Working temperature		°C min./max. 0/40	
Net calorific value G20 gas		kWh/Nm ³ 10	
G20 gas density		kg/Nm ³ 0,71	
G20 gas delivery		1,2/2,3 - 5,8	5,8/8,1 - 22
Net calorific value G25 gas		kWh/Nm ³ 8,6	
G25 gas density		kg/Nm ³ 0,78	
G25 gas delivery		1,4/2,7 - 6,7	6,7-9,4 - 25,6
Net calorific value LPG gas		kWh/Nm ³ 25,8	
LPG gas density		kg/Nm ³ 2,02	
LPG gas delivery		0,4/0,8 - 2,2	2,2/3,1 - 8,5
Fan		type Centrifugal with forward curve blades	
Air temperature		Max. °C 40	
Electrical supply		Ph/Hz/V 1/50/230 ±10%	
Auxiliary electrical supply		Ph/Hz/V --	
Control box		type MG 557/3	RMG 88.620A2
Total electrical power		kW 0,110	0,250
Auxiliary electrical power		kW --	
Protection level		IP X0D	
Motor electrical power		kW 0,09	0,15
Rated motor current		A 0,65	1,4
Motor start up current		A 2,6	5,6
Motor protection level		IP 20	
Ignition transformer		type	Incorporated in the control box Separated from the control box
		V1 - V2	(--) - 8 kV 230 V - 8 kV
		I1 - I2	(--) - 12 mA 1,8 A - 30 mA
Operation		Intermittent (at least one stop every 24 h)	
Sound pressure		dB(A) 60	73
Sound power		W --	
CO emission		mg/kWh <40	
NOx emission		mg/kWh ≤120	
Directive		90/396/EEC, 89/336/EEC, 73/23/EEC, 98/37/EEC, 92/42/EEC	
Conforming to		EN 676	
Certification		CE - 0063 AP6680	

Reference conditions:

Temperature: 20 °C

Pressure: 1013,5 mbar

Altitude: 100 m a.s.l.

Noise measured at a distance of 1 meter.

Since the Company is constantly engaged in the production improvement, the aesthetic and dimensional features, the technical data, the equipment and the accessories can be changed.
This document contains confidential and proprietary information of RIELLO S.p.A. Unless authorised, this information shall not be divulged, nor duplicated in whole or in part.



FIRING RATES

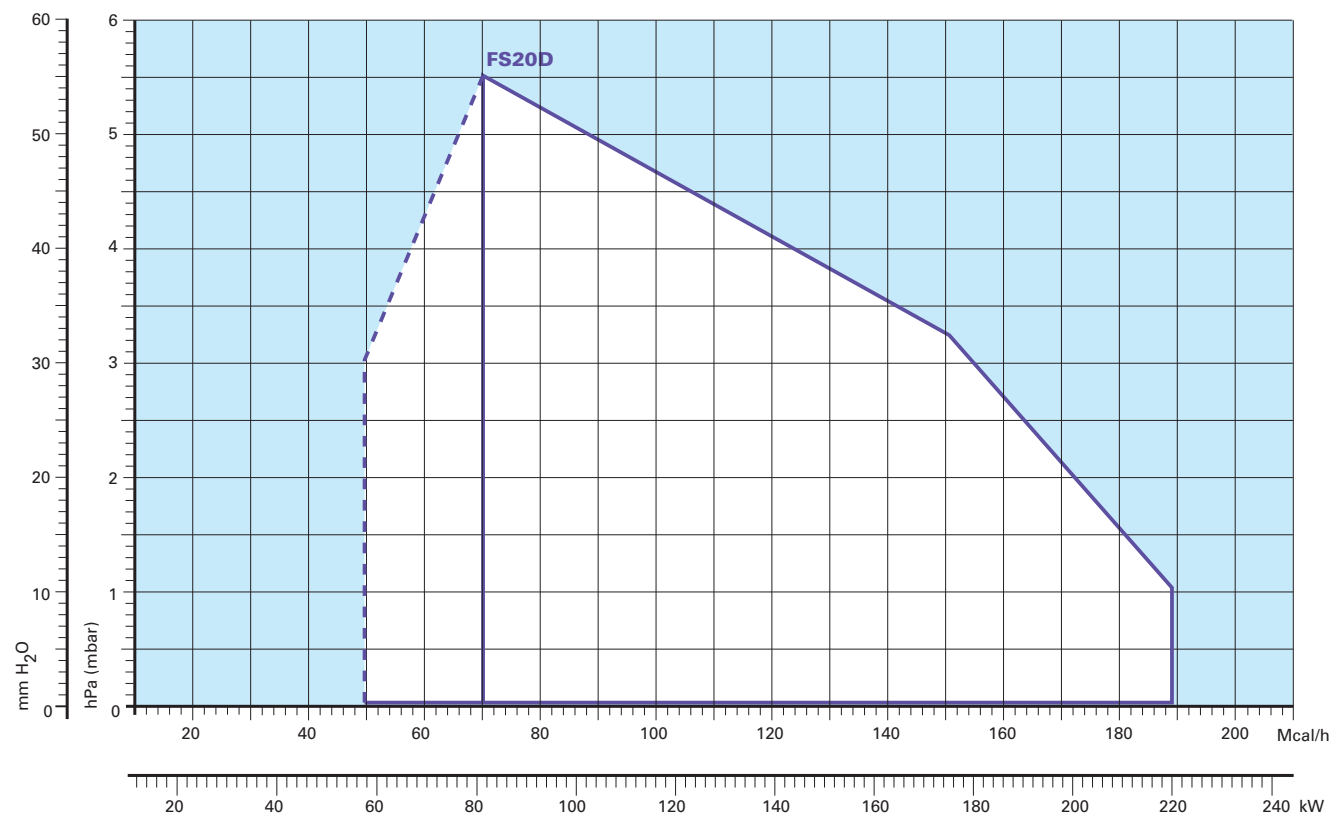
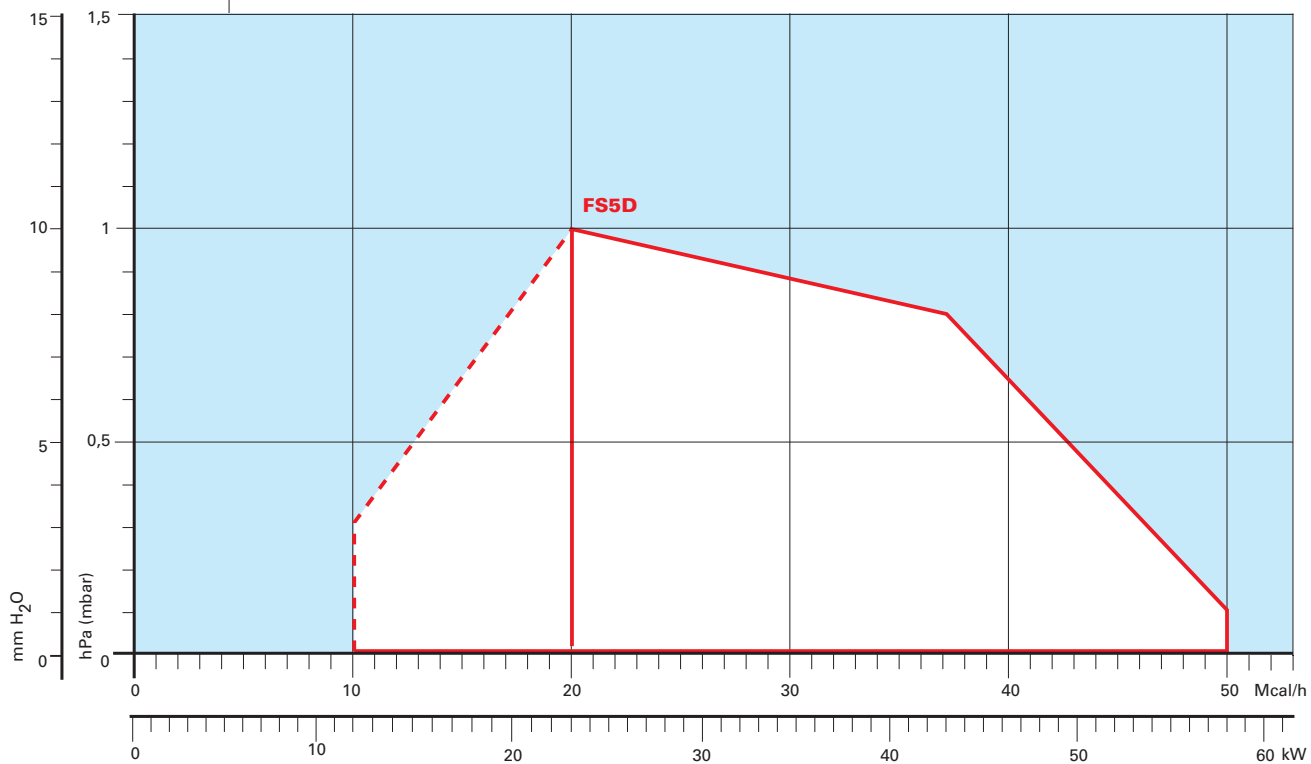

Useful working field for choosing the burner

1st stage operation range

Test conditions conforming to EN 676:

Temperature: 20 °C
 Pressure: 1013,5 mbar
 Altitude: 100 m a.s.l.





FUEL SUPPLY

GAS TRAIN

The burners are set for fuel supply from either the right or left hand sides.

Depending on the gas output and the available pressure in the supply line, you should check the correct gas train to be adapted to the system requirements.

The gas train is Multibloc type, containing the main components in a single unit and it can be fitted with the valves seal control (as accessory).



MBZRDLE 405 - 407 - 410

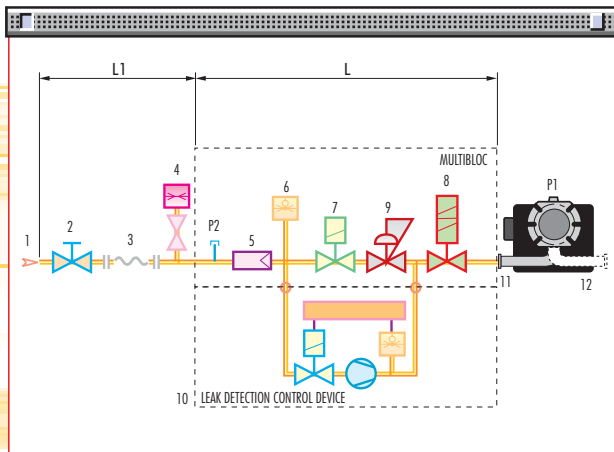

1	Gas delivery pipe
2	Manual valve
3	Vibration damping joint
4	Gas pressure gauge
5	Filter
6	Gas pressure switch
7	Safety solenoid
8	Adjustment solenoid 1st and 2nd stage: firing delivery adjustment (rapid opening) maximum delivery adjustment (slow opening)
9	Pressure regulator
10	Leak detection control device for valves 7 and 8 (accessory)
11	Gas train-burner adapter
12	Burner
P1	Combustion head pressure
P2	Upstream pressure from the filter
L	Gas train supplied separately
L1	To be performed by the installer

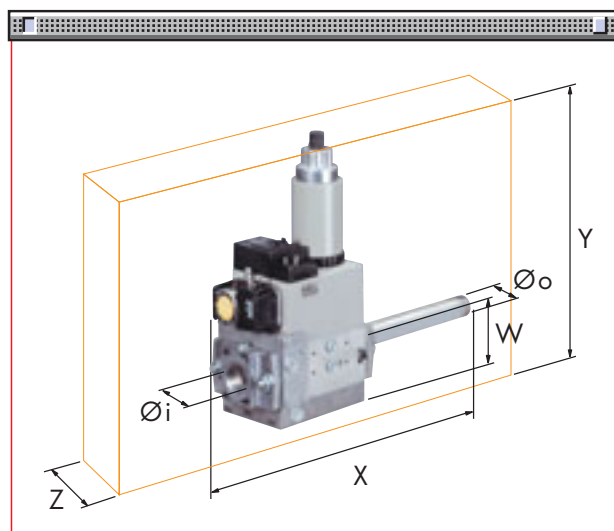

The dimensions of the gas trains vary depending on their construction features.

The following table shows the dimensions of the gas trains that can be fitted to Riello 40 FSD burners, intake and outlet diameters.

	Name	Code	Ø i	Ø o	X mm	Y mm	W mm	Z mm
MULTIBLOC	MBZRDLE 405	3970084	Rp 1/2"	Rp 1/2"	321	257	46	120
	MBZRDLE 407	3970537	Rp 3/4"	Rp 3/4"	371	257	46	120
	MBZRDLE 410	3970534	Rp 1"	Rp 3/4"	405	315	55	145



► PRESSURE DROP DIAGRAM

The diagrams indicate the minimum pressure drop of the burners with the various gas trains that can be combined with them; the value thus calculated represents the minimum required input pressure to the gas train.

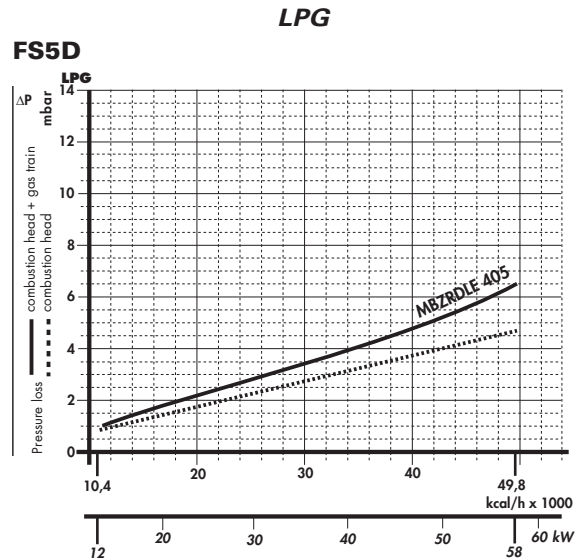
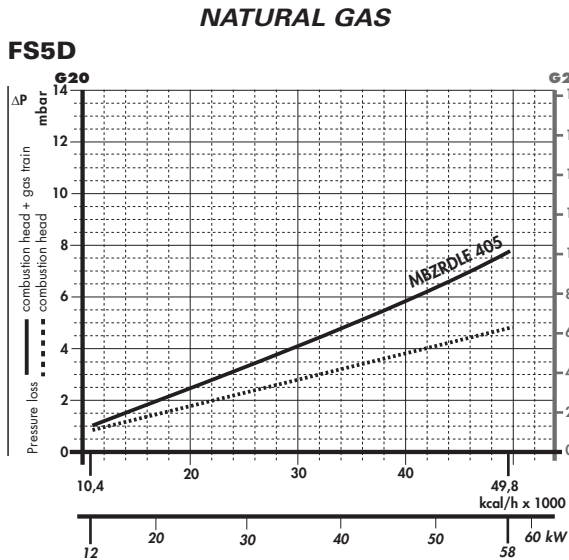

Gas train	Code	Terminal strip	Plug and socket
MBZRDLE 405	3970084		•

With installed plug (if the plug is not necessary, remove it in accordance with gas train instruction manual indication).

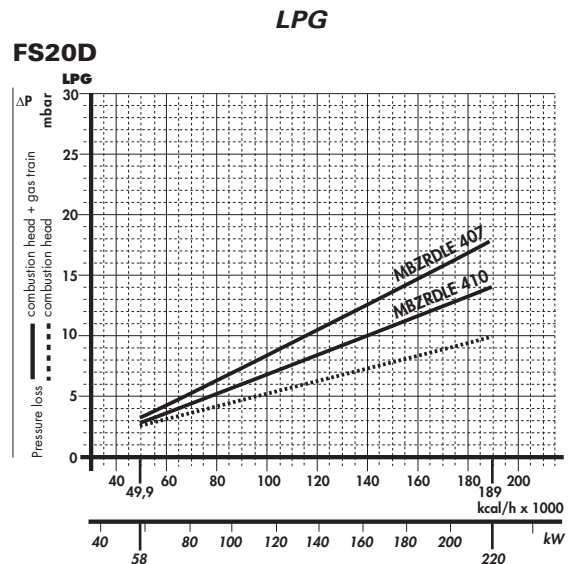
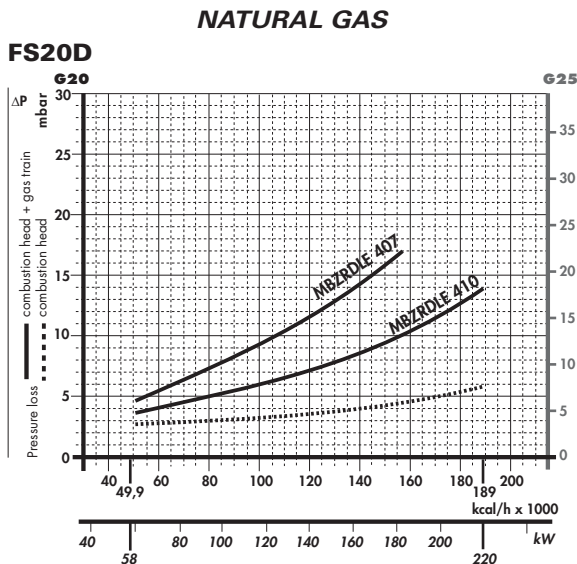

Gas train	Code	Output kW	Terminal strip	Plug and socket
MBZRDLE 407	3970537	≤ 180 (*)		•
MBZRDLE 410	3970534	-		•

(*) With natural gas.

With installed plug (if the plug is not necessary, remove it in accordance with gas train instruction manual indication).

► **note** For pressure levels different from those indicated above, please contact Riello Burners Technical Office.
In LPG plants, Multibloc gas trains do not operate below 0°C.
They are only suitable for gaseous LPG (liquid hydrocarbons destroy the seal materials).



SELECTING THE FUEL SUPPLY LINES

The following diagram enables pressure drop in a pre-existing gas line to be calculated and to select the correct gas train.

The diagram can also be used to select a new gas line when fuel output and pipe length are known. The pipe diameter is selected on the basis of the desired pressure drop. The diagram uses methane gas as reference; if another gas is used, conversion coefficient and a simple formula (on the diagram) transform the gas output to a methane equivalent (refer to figure A). Please note that the gas train dimensions must take into account the back pressure of the combustion chamber during operations.

Control of the pressure drop in an existing gas line or selecting a new gas supply line.

The methane output equivalent is determined by the formula fig. A on the diagram and the conversion coefficient.

Once the equivalent output has been determined on the delivery scale (\dot{V}), shown at the top of the diagram, move vertically downwards until you cross the line that represents the pipe diameter; at this point, move horizontally to the left until you meet the line that represents the pipe length.

Once this point is established you can verify, by moving vertically downwards, the pipe pressure drop on the bottom scale below (mbar).

By subtracting this value from the pressure measured on the gas meter, the correct pressure value will be found for the choice of gas train.

Example:

- gas used	G25
- gas output	9.51 mc/h
- pressure at the gas meter	20 mbar
- gas line length	15 m
- conversion coefficient	0.62 (see figure A)

- equivalent methane output $\dot{V} = \left[\frac{9.51}{0.62} \right] = 15.34 \text{ mc/h}$

- once the value of 15.34 has been identified on the output scale (\dot{V}), moving vertically downwards you cross the line that represents 1" 1/4 (the chosen diameter for the piping);
- from this point, move horizontally to the left until you meet the line that represents the length of 15 m of the piping;
- move vertically downwards to determine a value of 1.4 mbar in the pressure drop bottom scale;
- subtract the determined pressure drop from the meter pressure, the correct pressure level will be found for the choice of gas train;

- correct pressure = (20-1.4) = 18.6 mbar

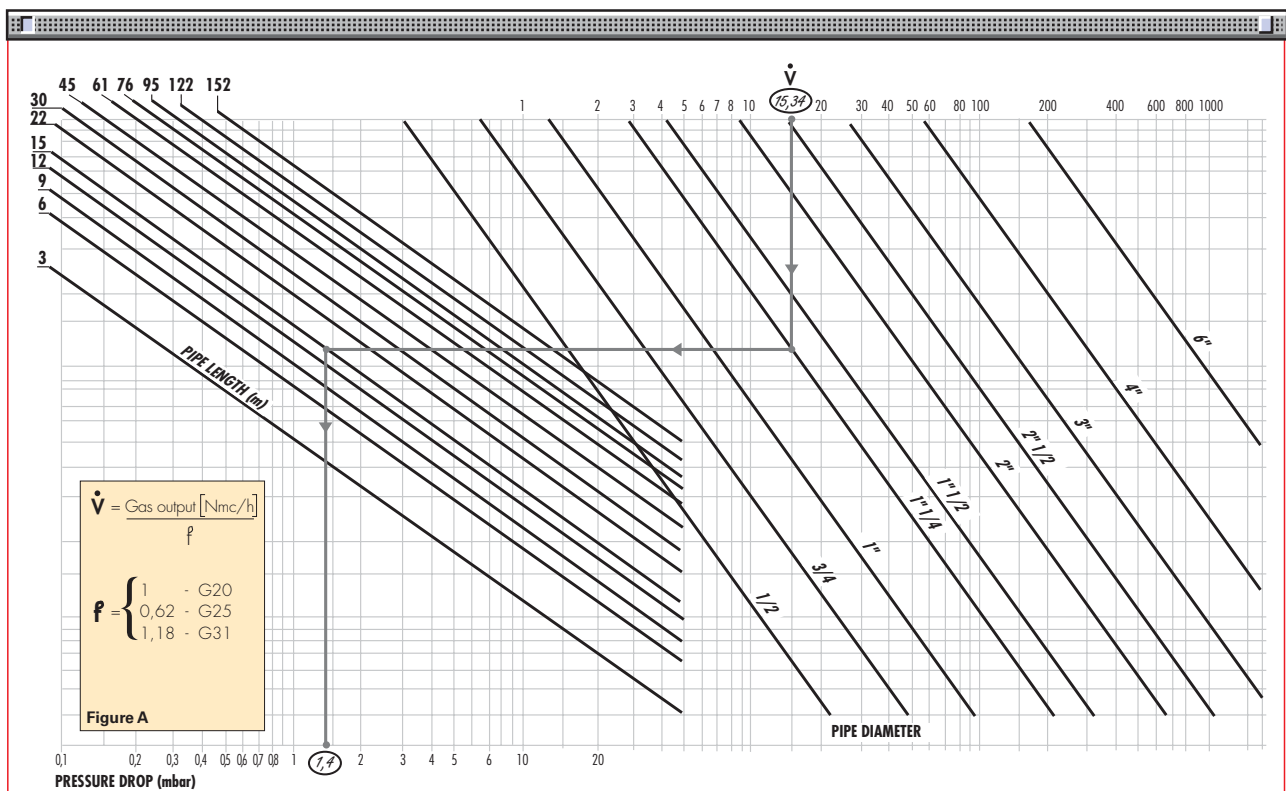

VENTILATION

The different ventilation circuits always ensure low noise levels with high performance of pressure and air delivery, in spite of their compact size.

The burners are fitted with an adjustable air pressure switch, conforming to EN 676 standards.



Air suction

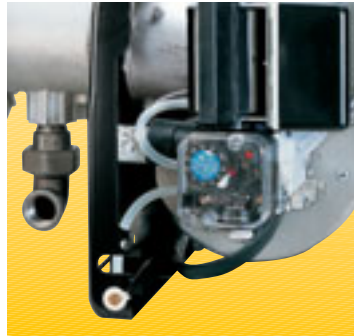

Air pressure switch

COMBUSTION HEAD

The combustion head in Riello 40 FSD burners is the result of an innovative design, which allows combustion with low polluting emissions, while being easy to adapt to all the various types of boilers and combustion chambers.



Combustion head



Flange

Simple adjustment allows the internal geometry of the combustion head to be adapted to the burner output.

Dimensions of the flame

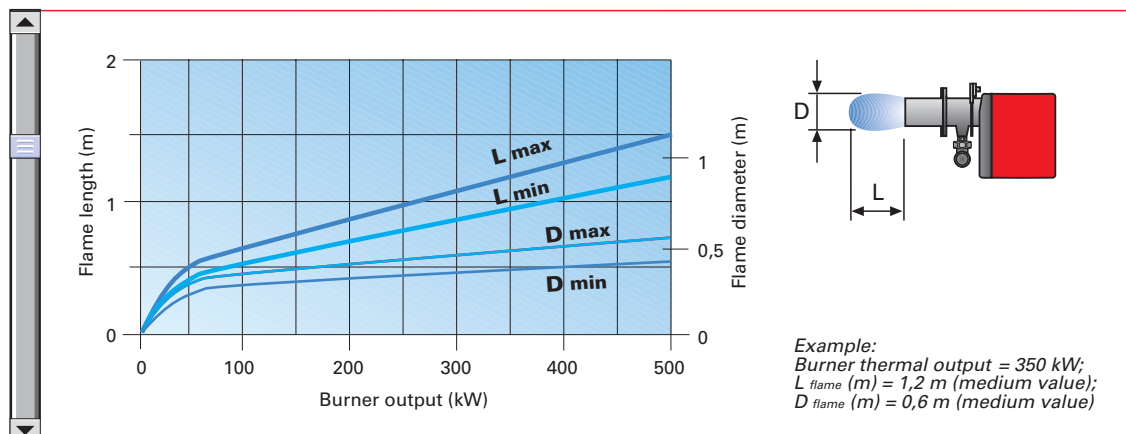

ADJUSTMENT



BURNER OPERATION MODE

All these models are two stage operation.

The Riello 40 FSD series of two stage burners allows operating at both full and

reduced output, with consequent reduction in turning the burner on and off, their giving better performance to the boiler. In the FS20D model, during stand-by, the air damper is completely closed (controlled by an electric servomotor) and prevents heat loss due to the flue draught.

Two stage operation

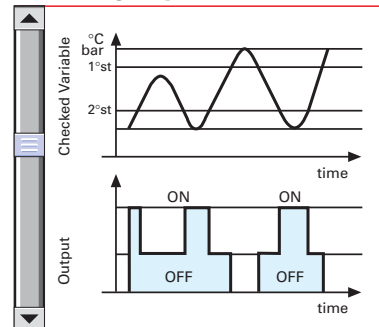

FS20D air damper adjustment



FS5D air damper partially open



FS5D air damper completely open

The FS5D model is fitted with the new MG 557 microprocessor control panel. For helping the commissioning and maintenance work, there are two main elements:



The lock-out reset button is the central **operating element** for resetting the burner control and for activating / deactivating the diagnostic functions.



The multi-color LED is the central **indication element** for visual diagnosis and interface diagnosis.

Both elements are located under the transparent cover of lock-out reset button, as showed below.

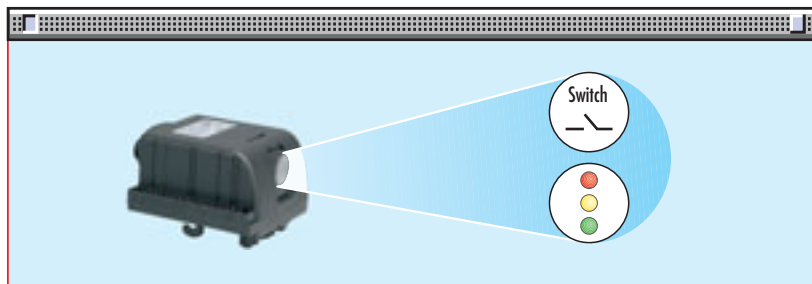

There are two diagnostic choices, for indication of operation and diagnosis of fault cause:

- **visual diagnosis:**

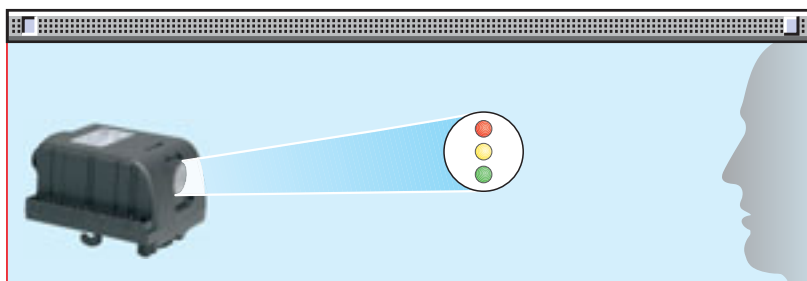



- interface diagnosis:

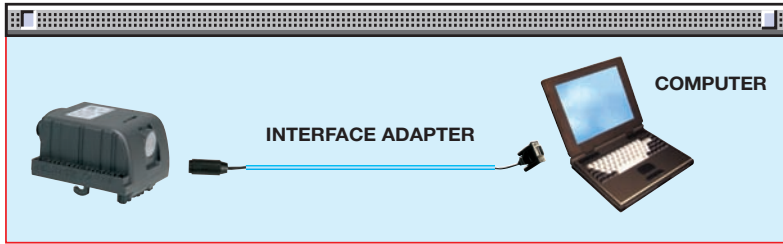

by the interface adapter and a PC with dedicated software.

Indication of operation:

Color code table	
Operation status	Color code
Stand-by	○ Led off
Pre-purging	● Green
Ignition phase	● Green
Flame OK	● Green
Post purge	● Green
Undervoltage, built-in fuse	○ Led off
Fault, alarm	● Red
Flame simulation	○ Led off

In normal operation, the various status are indicated in the form of colour codes according to the table below.

Diagnosis of fault causes:

After lock-out has occurred, the red signal lamp is steady on. In this status, the visual fault diagnosis according to the error code table can be activated by pressing the lock-out reset button for > 3 seconds. The interface diagnosis (with adapter) can be activated by pressing again the lock-out button for > 3 seconds.

Example of flashes sequence:

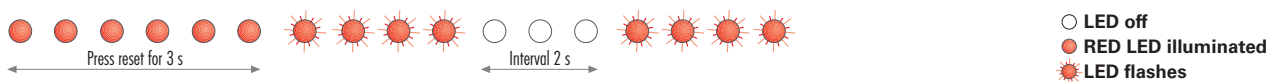

Error code table	
Signal	Probable cause
2 flashes ✖ ✖	The flame does not stabilise at the end of the safety time: - faulty ionisation probe - faulty or soiled gas valves - neutral/phase exchange - faulty ignition transformer - poor burner regulation (insufficient gas)
3 flashes ✖ ✖ ✖	Min. air pressure switch does not close or is already closed before the limit thermostat closed: - air pressure switch faulty - air pressure switch incorrectly regulated
4 flashes ✖ ✖ ✖ ✖	Presence of flame: - in stand-by position after heat demand - during pre-purging
6 flashes ✖ ✖ ✖ ✖ ✖ ✖	Loss air pressure: - during pre-purging - during safety time or operations
7 flashes ✖ ✖ ✖ ✖ ✖ ✖ ✖	Loss of flame 4 times during operations after 3 attempts of re-cycle: - poor burner regulation (insufficient gas) - faulty or soiled gas valves - short circuit between ionisation probe and earth - faulty ionisation probe



The FS20D model is fitted with a new microprocessor control panel for the supervision during intermittent operation.

For helping the commissioning and maintenance work, there are two main elements:



The lock-out reset button is the central **operating element** for resetting the burner control and for activating / deactivating the diagnostic functions.



The multi-color LED is the central **indication element** for visual diagnosis and interface diagnosis.

Both elements are located under the transparent cover of lock-out reset button, as showed below.



There are two diagnostic choices, for indication of operation and diagnosis of fault cause:

- visual diagnosis :

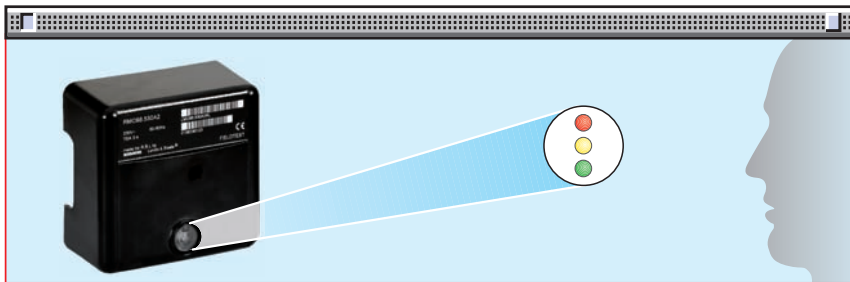

- interface diagnosis :



by the interface adapter and a PC with dedicated software or by a predisposed flue gas analyzer (see paragraph accessories).

Indication of operation :

Color code table	
Operation status	Color code table
Stand-by	○ ○ ○ ○ ○ ○ ○ ○
Pre-purging	☀ ☀ ☀ ☀ ☀ ☀ ☀ ☀
Ignition phase	☀ ○ ☀ ○ ☀ ○ ☀ ○
Flame OK	☘ ☘ ☘ ☘ ☘ ☘ ☘ ☘
Poor flame	☘ ○ ☘ ○ ☘ ○ ☘ ○
Undervoltage, built-in fuse	☀ ☘ ☀ ☘ ☀ ☘ ☀ ☘
Fault, alarm	☘ ☘ ☘ ☘ ☘ ☘ ☘ ☘
Extraneous light	☘ ☘ ☘ ☘ ☘ ☘ ☘ ☘

In normal operation, the various status are indicated in the form of colour codes according to the table below. The interface diagnosis (with adapter) can be activated by pressing the lock-out button for > 3 seconds.

○ LED off



Diagnosis of fault causes :

After lock-out has occurred, the red signal lamp is steady on. In this status, the visual fault diagnosis according to the error code table can be activated by pressing the lock-out reset button for > 3 seconds. The interface diagnosis (with adapter) can be activated by pressing again the lock-out button for > 3 seconds.

The flashes of red LED are a signal with this sequence :

(e.g. signal with n° 3 flashes – faulty air pressure monitor)



Error code table	
Possible cause of fault	Flash code
No establishment of flame at the end of safety time : - faulty or soiled fuel valves - faulty or soiled flame detector - poor adjustment of burner, no fuel - faulty ignition equipment	2 flashes
Faulty air pressure monitor	3 flashes
Simulation of flame on burner start up	4 flashes
Loss of flame during operation : - faulty or soiled fuel valves - faulty or soiled flame detector - poor adjustment of burner	7 flashes
Wiring error or internal fault	10 flashes

START UP CYCLE

FS5D

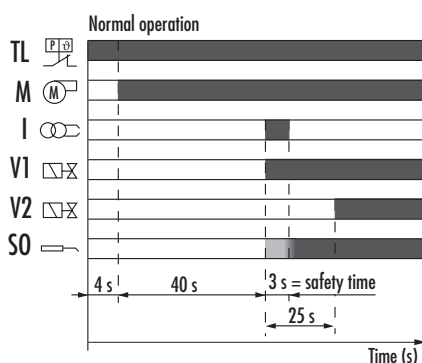

Correct operation

- 0s The burner begins the ignition cycle
- 0s-4s The control box waits still after the heat request
- 4s-44s Pre-purging time with strat of the fan motor
- 44s-47s Safety time as total ignition time.
The 1st stage valve opens
- 44s-69s Delay time between 1st stage and 2nd stage.
2nd stage valve opening after the 1st stage valve opening.

If the flame does not light for 4 times within the safety limit time (3 sec), the burner lock-out.

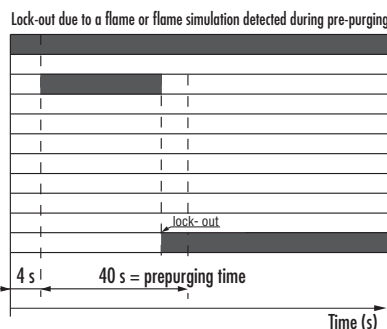
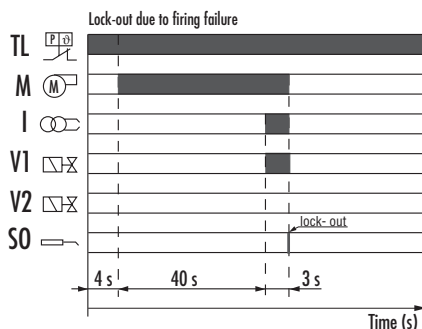

FS20D

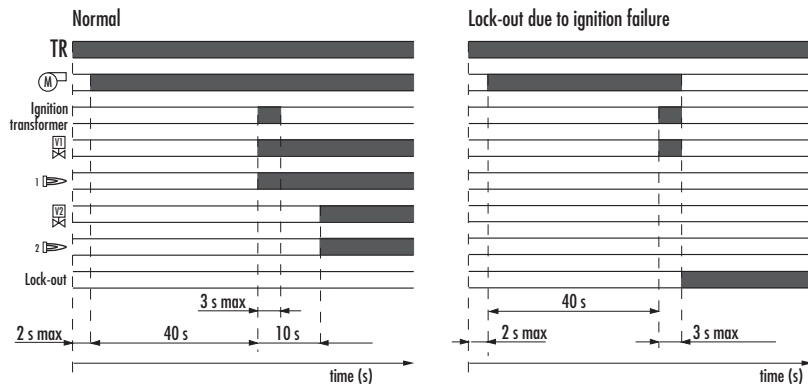

Correct operation

- 0s The burner begins the ignition cycle
- 0s-2s Safety time
- 2s-42s Pre-purge with the air damper open
- 42s-45s Ignition 1st stage
- 52s Ignition 2nd stage.

Lock-out due to ignition failure

If the flame does not light within the safety limit (~3s) the burner locks-out.

When flame-failure occurs during working, shut down takes place within one second.



WIRING DIAGRAMS

Electrical connections must be made by qualified and skilled personnel in conformity with the local regulations in force. The models are fitted with terminal strip for all the electrical connections.

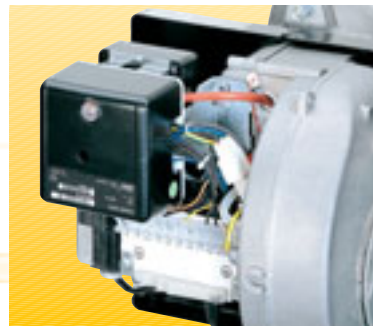

FS20D control box and separated ignition transformer

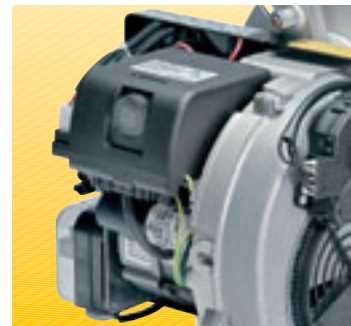

FS5D control box with integrated ignition transformer

TWO STAGE OPERATION

Burner electrical wiring

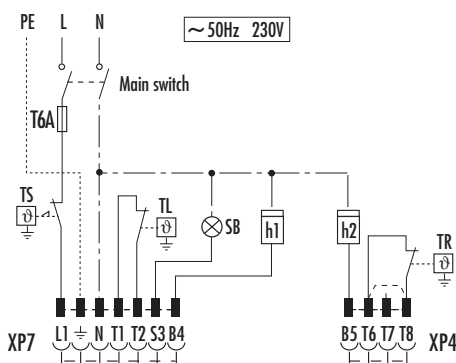

FS5D

Gas train electrical wiring

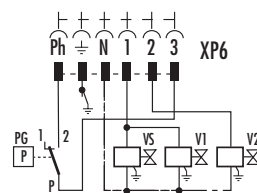

- h1** - 1st stage hour counter (230V - 0,1A max.)
- h2** - 2nd stage hour counter (230V - 0,1A max.)
- PG** - Minimum gas pressure switch (230V - 0,5A max.)
- SB** - Remote lock-out signal (230V - 0,5A max.)
- TL** - Limit thermostat
- TS** - Safety thermostat
- TR** - 2nd stage thermostat
- T6A** - Fuse
- V1** - 1st stage valve
- V2** - 2nd stage valve
- VS** - Safety valve
- XP4** - 4 pin plug/socket
- XP6** - 6 pin plug/socket
- XP7** - 7 pin plug/socket



FS20D

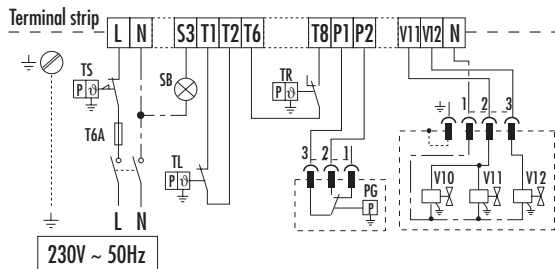

- PG** - Minimum gas pressure switch
- SB** - Remote lock-out signal (230V - 0,5A max.)
- T6A** - Fuse
- TL** - Limit thermostat
- TS** - Safety thermostat
- TR** - 2nd stage thermostat
- V10** - Safety valve
- V11** - 1st stage valve
- V12** - 2nd stage valve

Electrical wiring with gas leak control device (DUNGS VPS 504)

FS5D

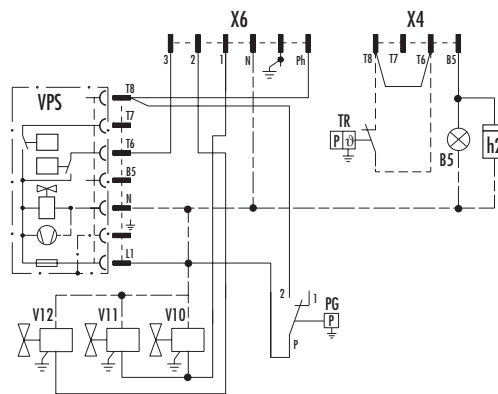
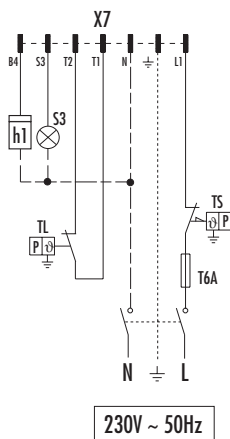

- B5** - 2nd stage lock-out signal
- h1** - 1st stage Hour counter
- h2** - 2nd stage Hour counter
- PG** - Min. gas pressure switch
- S3** - Remote lock-out signal (230V - 0.5 A max.)
- T6A** - Fuse
- TL** - Limit thermostat
- TR** - 2st stage thermostat
- TS** - Safety thermostat
- V10** - Safety valve
- V11** - 1st stage valve
- V12** - 2nd stage valve
- X4** - 4 pin plug
- X6** - 6 pin plug
- X7** - 7 pin plug

FS20D

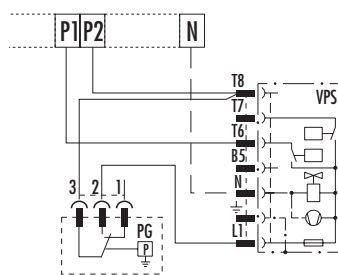

The following table shows the supply lead sections and types of fuse to be used.

Model	▼ FS5D	▼ FS20D
	230V	230V
F A	T6	T6
L mm ²	1	1

F = Fuse

L = Lead section



EMISSIONS

The emission data have been measured in the various models at maximum output, in conformity with EN 676 standard.

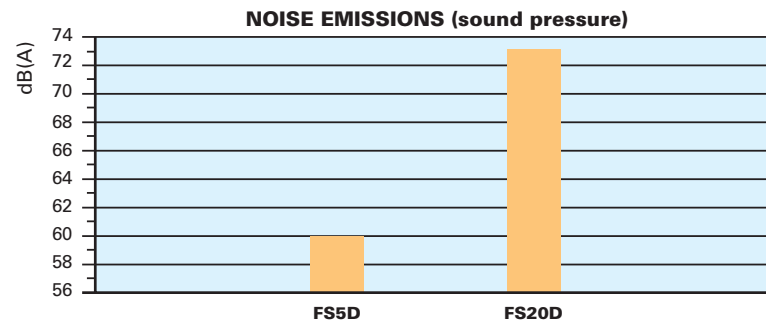
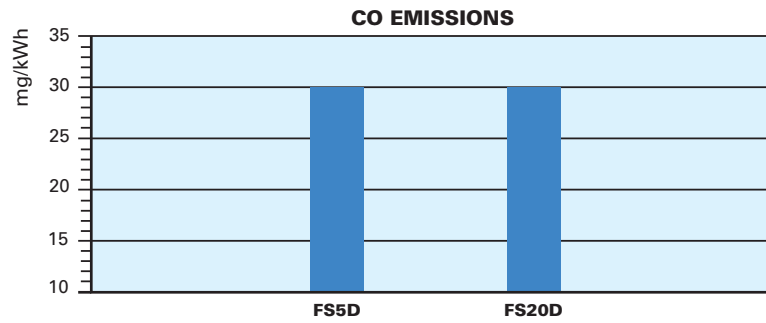
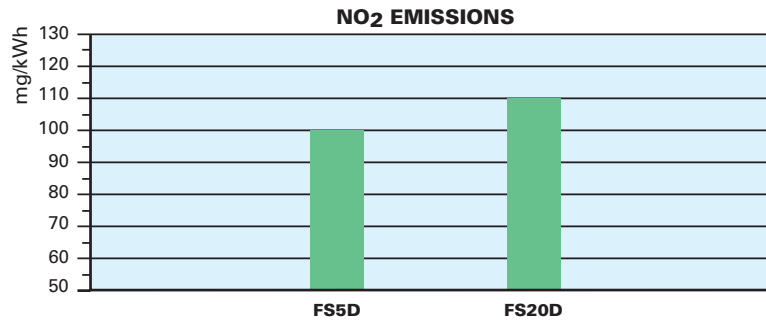

OVERALL DIMENSIONS (mm)

These models are distinguished by their reduced size, in relation to the outputs achieved, which means they can be fitted to any boiler actually on the market.



BURNER

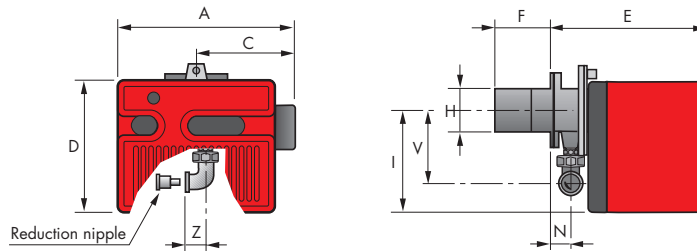

Model	A	C	D	E	F	H	I	N	V	Z
▶ FS5D	306	170	233	295	100	91	180	48	138	28
▶ FS20D	413	238	298	389	120	125	230	67	152	33

BURNER-BOILER MOUNTING FLANGE

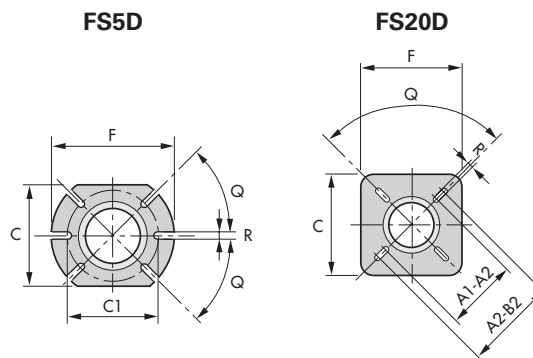

Model	A1	A2	B1	B2	C	C1	F	Q	R
▶ FS5D	-	-	-	-	140	130	170	45	10
▶ FS20D	155	200	155	200	170	-	170	90	11

PACKAGING

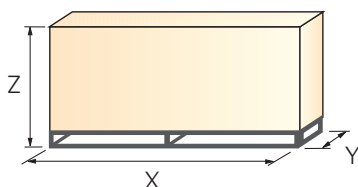

Model	X	Y	Z	kg
▶ FS5D	435	345	315	11
▶ FS20D	525	525	365	22



INSTALLATION DESCRIPTION

Installation, start up and maintenance must be carried out by qualified and skilled personnel.
All operations must be performed as described in the technical handbook supplied with the burner.
The burner is set in the factory on standard calibration (minimum output). If necessary adjustments can be made on the basis of the maximum output of the boiler.

BURNER SETTING

- ▶ The air damper position is easy to set, and in the FS20D can be adjusted without removing the burner cover.
- ▶ Head setting is easy and aided by a graduated scale; a test point allows reading the air pressure in the combustion head.
- ▶ Riello 40 FSD burners are fitted with an air pressure switch which, in accordance with EN 676 standards, can be adjusted by the installer using a graduated selector, on the basis of the effective working conditions.



MAINTENANCE

- ▶ The maintenance position is easily carried out by hinge that joins the body of burner to the flange.



BURNER ACCESSORIES



Extended head kit

“Standard head” burners can be transformed into “extended head” versions by using the special kit. Below the KITS available for the various burners are listed, showing the original and the extended lengths.

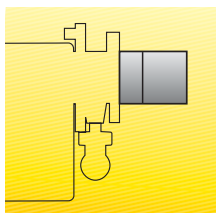

Extended head kit			
Burner	Standard head length (mm)	Extended head length (mm)	Kit code
FS5D	100	125	3000820
FS20D	120	280	3000873

End cone with turbulator disk

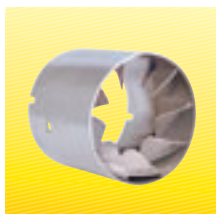

End cone with turbulator disk		
Burner	Projection (mm)	Kit code
FS5D	+15	3000916
FS20D	+23	3000919

Town gas kit

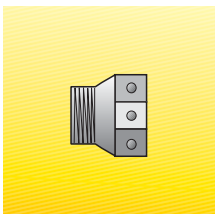

Town gas kit	
Burner	Kit code
FS5D	3000889
FS20D	3000893

LPG kit

For burning LPG gas, a special kit is available to be fitted to the combustion head on the burner, as shown in the following table:

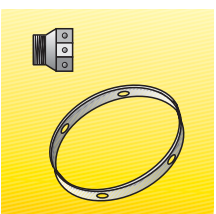

LPG kit		
Burner	Kit code for standard head	Kit code for extended head
FS5D	3000882	3000882
FS20D	3000886	3000886



Remote reset control kit for MG 557/3 control box

The MG 557 control box can be remotely released using an electric command kit. This kit must be installed in conformity with current regulations in force.

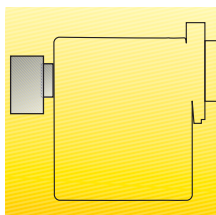

Remote reset control kit for MG 557/3 control box	
Burner	Kit code
FS5D	3002750

PC interface kit

To connect the flame control panel to a personal computer for the transmission of operation, fault signals and detailed service information, an interface adapter with PC software are available.



PC interface kit	
Burner	Kit code
FS20D	3002719

7-pin plug kit

If necessary a 7-pin plug kit is available (in packaging of n. 5 pieces).

7-pin plug kit	
Burner	Kit code
FS5D - FS20D	3000945

Continuous ventilation kit for RMG control box

If the burner requires continuous ventilation in the stages without flame, a special kit is available as given in the following table.

Continuous ventilation kit for RMG control box	
Burner	Kit code
FS20D	3010094



GAS TRAIN ACCESSORIES



Seal control kit

To test the valve seals on the gas train, a special "seal control kit" is available.



Seal control kit	
Burner	Kit code
FS5D - FS20D	3010123



SPECIFICATION



A special index guides your choice of boiler from the various models available in the Riello 40 FSD series. Below is a clear and detailed specification description of the product.



► DESIGNATION OF SERIES

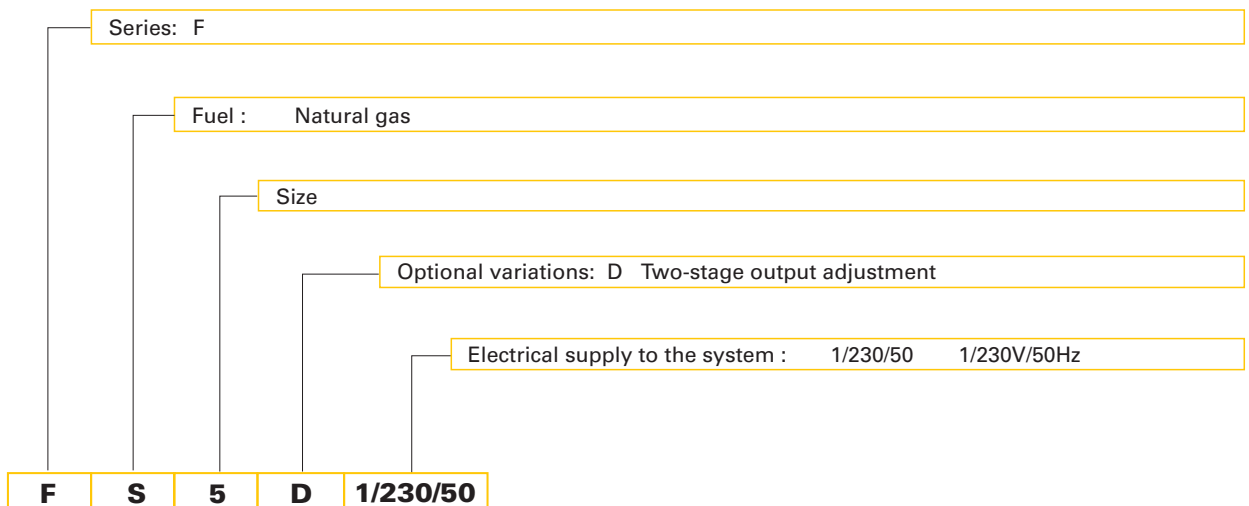

► AVAILABLE BURNER MODELS

FS5D	1/230/50
FS20D	1/230/50



▶ PRODUCT SPECIFICATION

Burner

Monoblock, gas burners, completely automatic, with two stage settings fitted with:

- Fan with forward curve blades
- Metallic cover
- Air damper, completely closed in stand by, driven by an electric servomotor
- Air damper with 1st and 2nd stage adjustment
- Single phase electric motor 230 V, 50 Hz
- Combustion head fitted with:
 - stainless steel head cone, resistant to high temperatures
 - ignition electrodes
 - ionisation probe
 - gas distributor
 - flame stability disk
- Adjustable air pressure switch, with graduated selector, to guarantee burner lock out in the case of insufficient combustible air
- Microprocessor-based flame control panel MG 557 (with diagnostic, remote reset, continuous purge integrated, recycle, post-purge)
- IP X0D electric protection level.

Gas train

Fuel supply line in the Multibloc configuration, fitted with:

- Filter
- Pressure stabiliser
- Minimum gas pressure switch
- Safety valve
- Two stage working valve with ignition gas output regulator.

Approval:

- EN 676 standard.

Conforming to:

- 90/396/EEC (gas)
- 73/23/EEC (low voltage)
- 89/336/EEC (electromagnetic compatibility)
- 92/42/EEC (efficiency)
- 98/37/EEC (machines).

Standard equipment:

- Insulating gasket
- Screws and nuts for fixing the flange to the boiler
- Instruction handbook for installation, use and maintenance
- Spare parts catalogue
- Hinge
- Cable grommet.

Available accessories to be ordered separately:

- Extended head kit
- End cone with turbolator disk
- Town gas kit
- LPG kit
- PC interface kit
- 7-pin plug kit
- Continuous ventilation kit for RMG control box
- Remote reset kit for MG 557 control box
- Seal control kit.









RIELLO S.p.A. - Via Ing. Pilade Riello, 5 - 37045 Legnago (VR) Italy
Tel. ++39.0442630111 - Fax ++39.044221980

Internet: <http://www.rielloburners.com> - E-mail: info@rielloburners.com

Since the Company is constantly engaged in the production improvement, the aesthetic and dimensional features, the technical data, the equipment and the accessories can be changed.
This document contains confidential and proprietary information of RIELLO S.p.A.
Unless authorised, this information shall not be divulged, nor duplicated in whole or in part.

